

# KEY-802

## MAGAZINE DIAGRAM

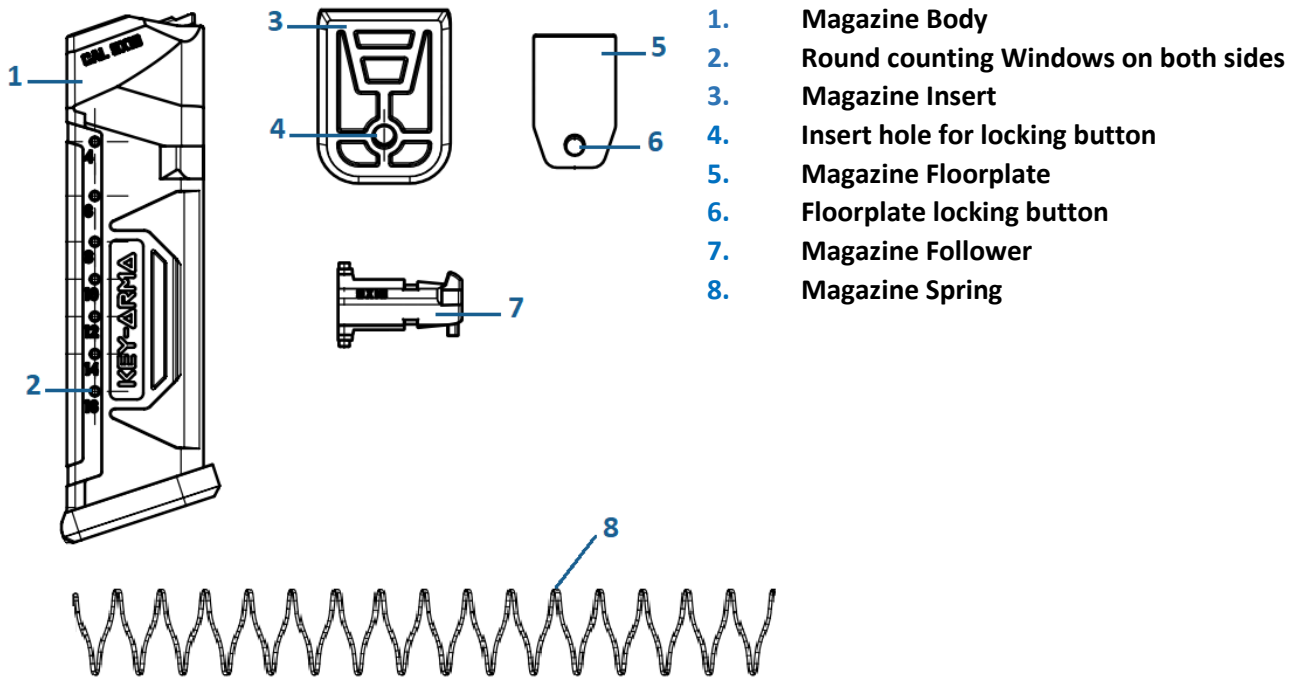

### How to disassemble, clean and reassemble

**WARNING:** Make sure the firearm is unloaded before installation.



1. Simply press the locking button (6) and remove carefully the spring, floorplate and follower. After you cleaned the magazine reassemble as it was removed. Make sure that the locking button (6) has placed on the insert locking hole (4).

KEY-802	Length	Width	Height
Dimensions	3.97 cm	2.85 cm	12.77 cm
Weight	48 gr		

TECHNICAL DIMENSIONS

