

# ALPHA-CP

## STOCK DIAGRAM

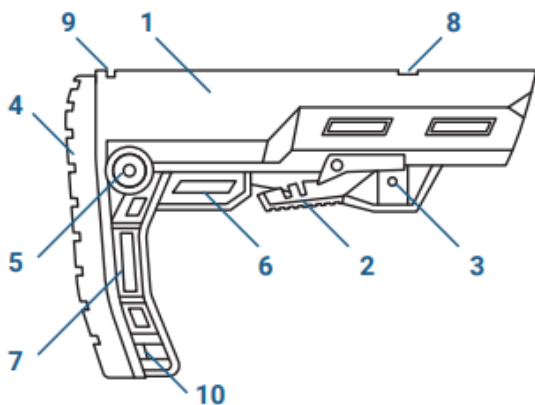

1. Buttstock
2. Buttstock locking button
3. Buttstock pin
4. Buttpad
5. QD cup for quick-detachable sling swivel (QD)
6. Slot for sling or cheek riser installation
7. Sling slot
8. Buttstock position indicator
9. Buttpad Groove
10. Buttpad fixing screw

## How to Install

**WARNING:** Make sure the firearm is unloaded before installation.

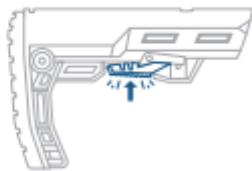

1. Press the install button (2) to the second level hard until you hear the sound.

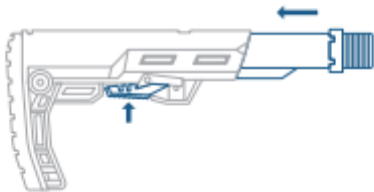

2. While holding the locking button (2), insert the buffer tube inside the stock.

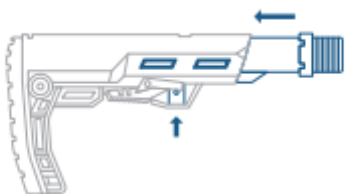

3. The buffer tube must pass through the fixing pin (3)

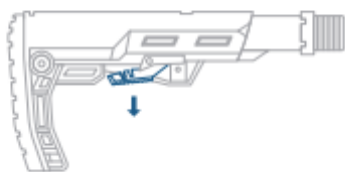

4. Release the buttstock lock button (2)

## Adjusting the buttstock

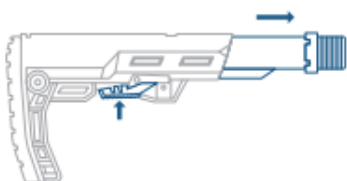

- Lightly press the buttstock lock button (2) to the first level and extend the buttstock to the required length. Then, release the buttstock lock button

### Cheek riser installatoin

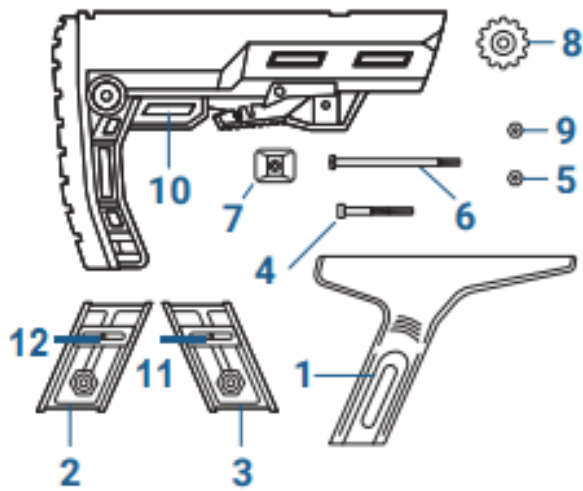

1. Cheek riser
2. Cheek riser rail (Left Piece)
3. Cheek riser rail (Right Piece)
4. Mounting bolt of cheek riser rail
5. Mounting nut of cheek riser rail
6. Mounting bolt fort the cheek riser wings
7. Clamping plate
8. Wing knob for adjusting the cheek riser
9. Nut for the wing knob
10. Slot for cheek riser installation
11. Hole for the cheek riser mounting bolt
12. Hole for the cheek riser mounting bolt

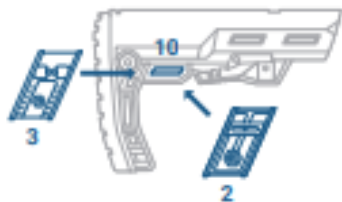

1. Insert the left (2) and right (3) rails of the cheek riser into the installation slot (10).

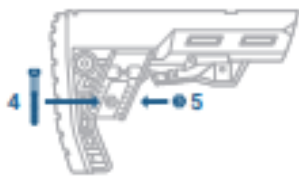

2. Secure the left (2) and right (3) rails using the nut (5) and bolt (4).



3. Insert the cheek riser (1) on to the rail (2, 3) and lower it until it stops.



4. Insert the wing bolt (6) through the plate (7). Insert the bolt into the cheek riser (11, 12), and place the wing nut (9) in to the wing knob (8) and turn the knob clockwise to the other end.

ALPHA-CP BUTTSTOCK	<b>Length</b>	<b>Width</b>	<b>Height</b>
<b>Dimensions</b>	20 cm	4.7 cm	13.7 cm
<b>Weight</b>	350 gr		

TECHNICAL DIMENSIONS

